

PR1 -

## polycarbonate screens, rail-mounted doors

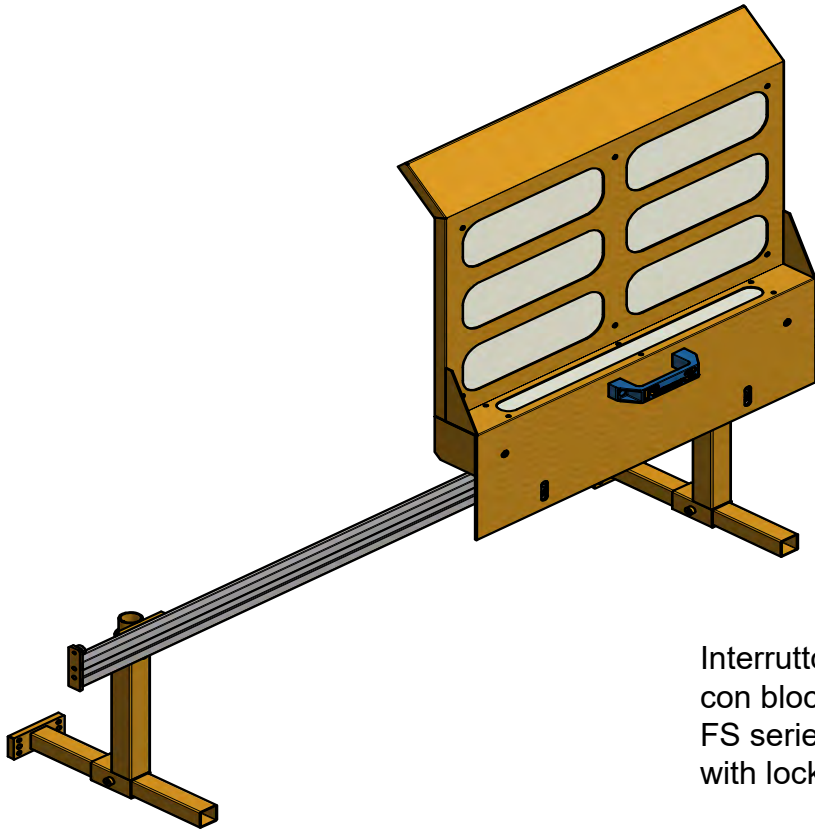

FS 3096D024



Interruttore di sicurezza ad azionatore separato  
con blocco serie FS.

FS series safety switch with separate actuator  
with lock

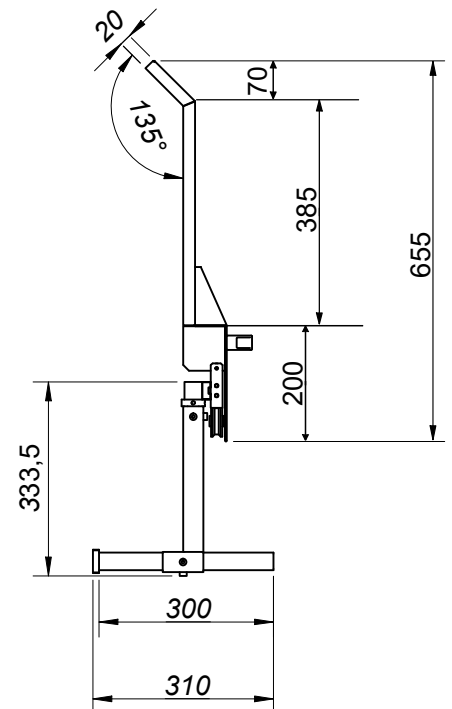
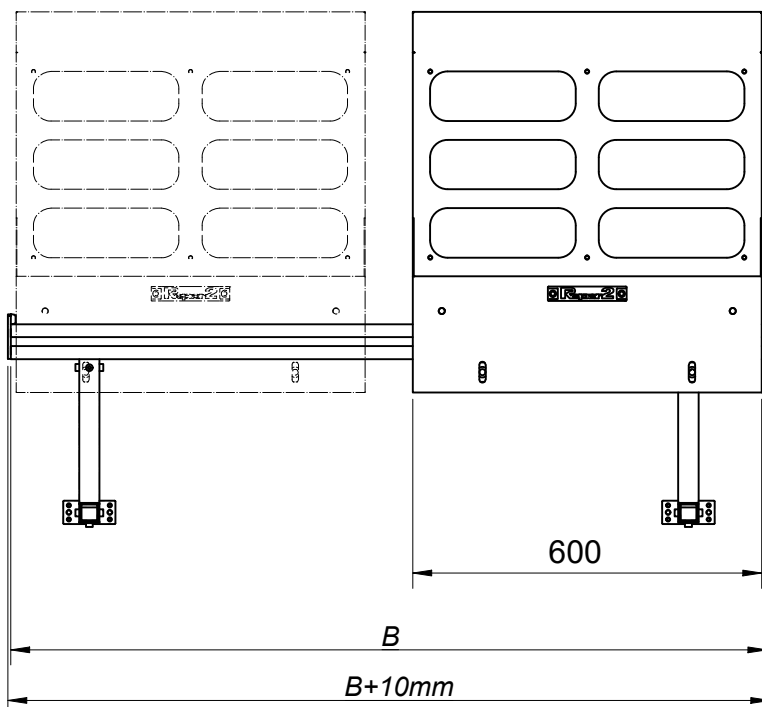

# PR2 - polycarbonate screens, rail-mounted doors

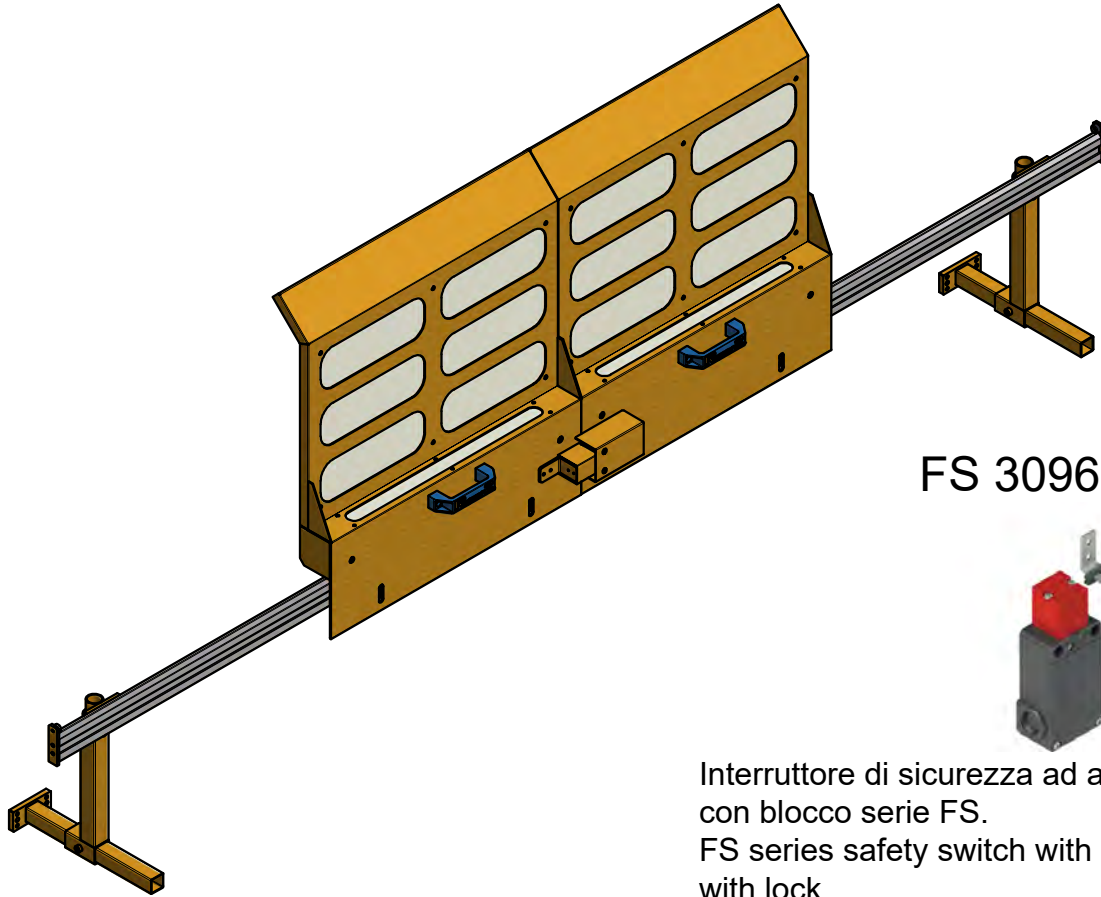

FS 3096D024



Interruttore di sicurezza ad azionatore separato  
 con blocco serie FS.  
 FS series safety switch with separate actuator  
 with lock

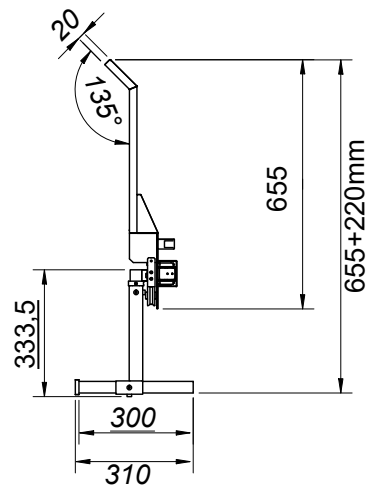
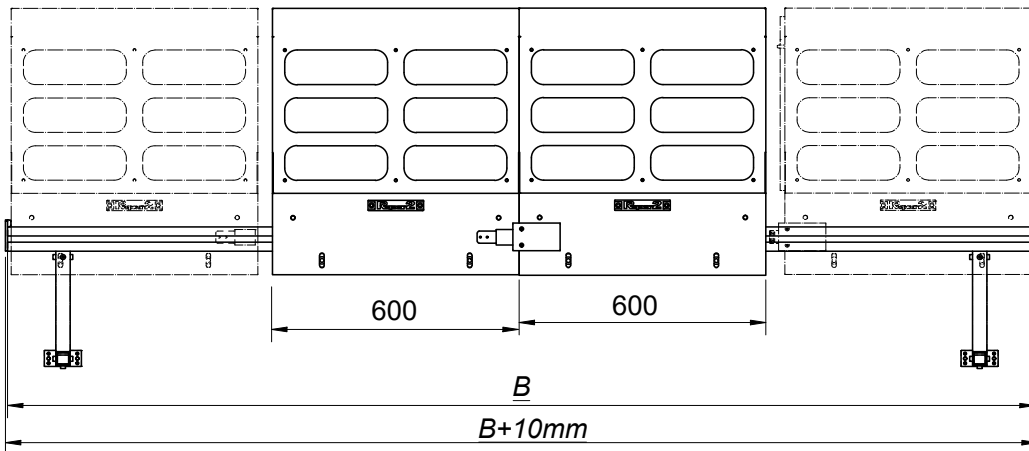

# Mod.PR

## Staffe di fissaggio

### Fixing brackets

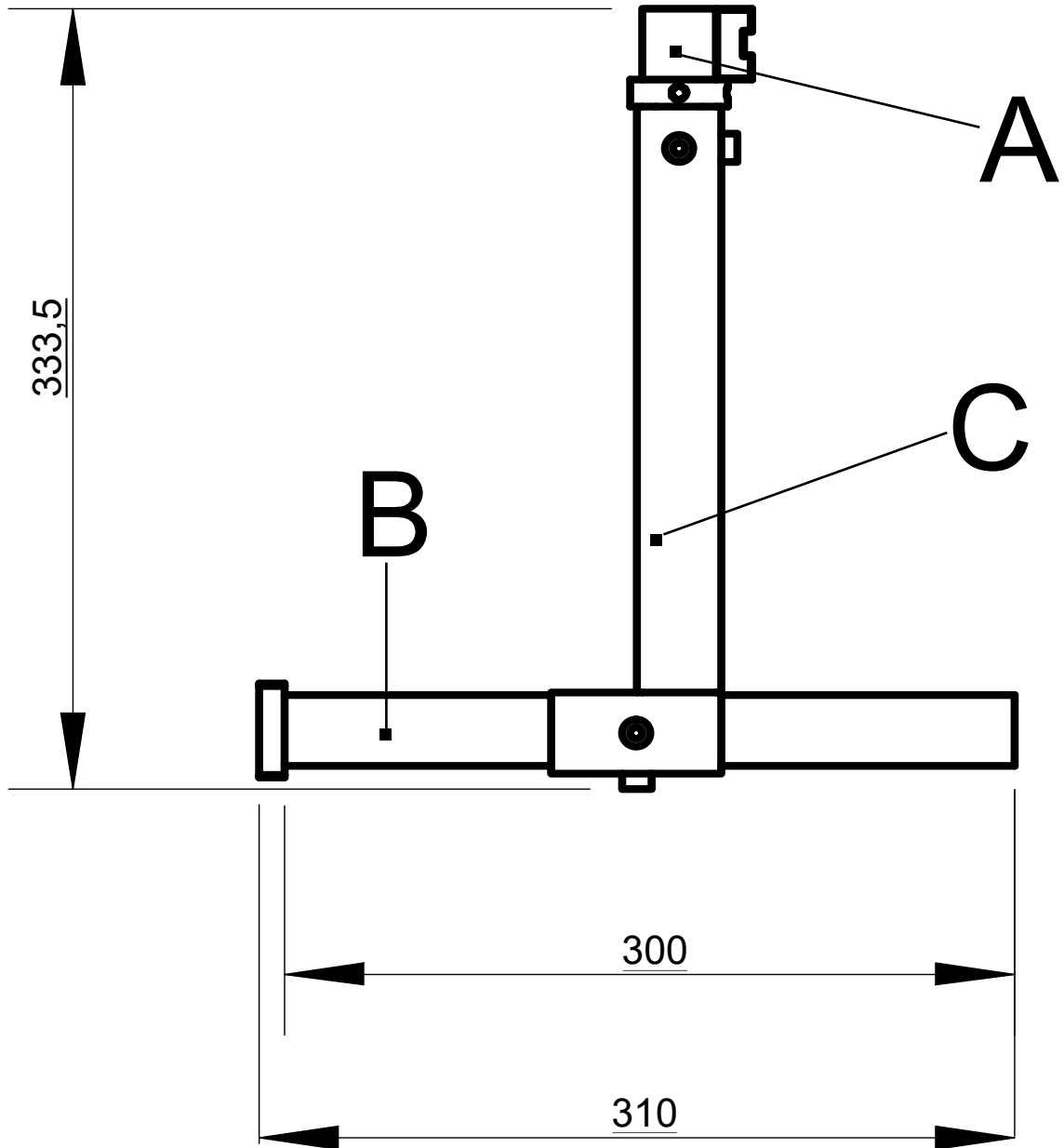

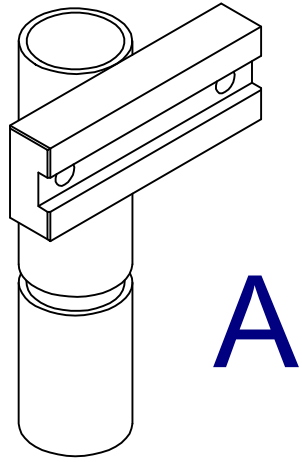
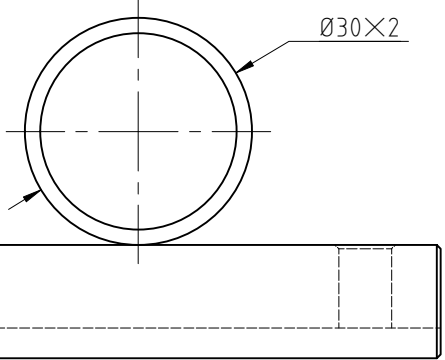
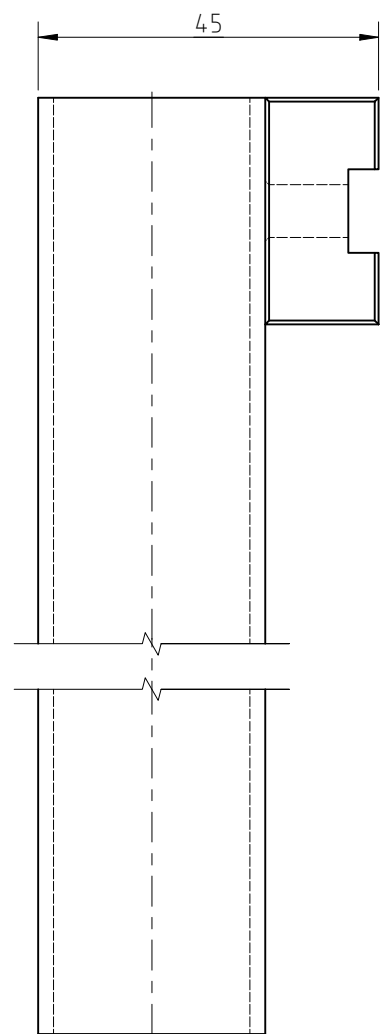
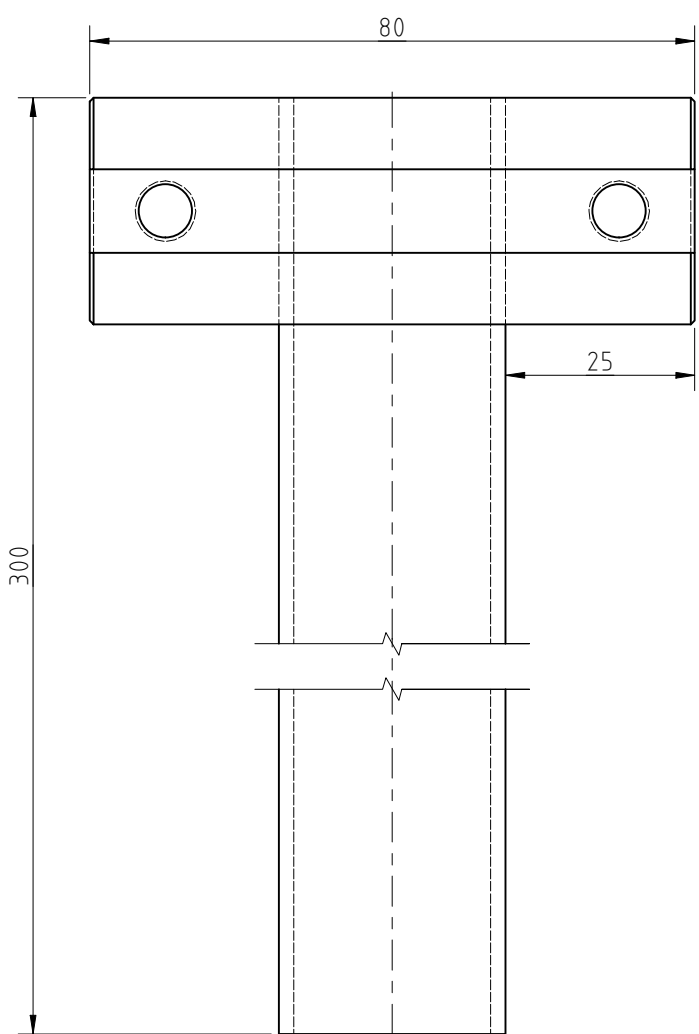

|  |  |                          |                     |                            |
|--|--|--------------------------|---------------------|----------------------------|
| Titolo:  |  |                          |                     |                            |
| Progetto:<br><b>REPAR2 PR</b>                        | Colore:  | Massa:<br>0,662 kg       | Data:<br>13/11/2022 | Scala principale:<br>1 : 1 |
| Tolleranze dimensionali generali:<br>UNI EN 22768-cL | Descrizione:<br><b>Assieme saldato. Attacco Guida</b><br>Welded assembly. Connection Guide | Numero disegno:<br>005PR |                     |                            |
|  |  |                          |                     |                            |



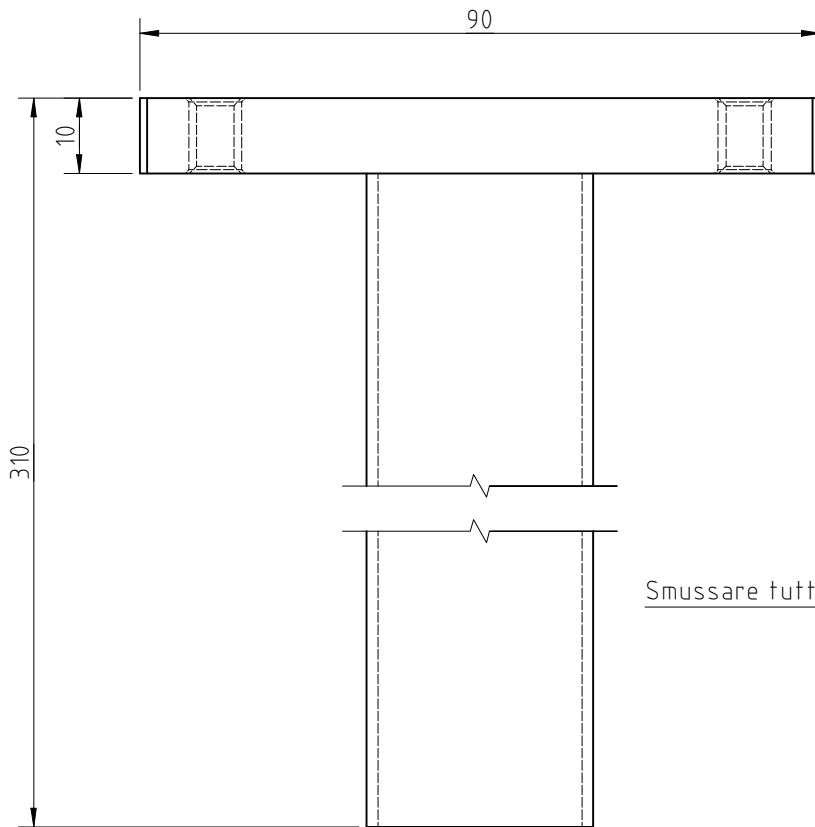
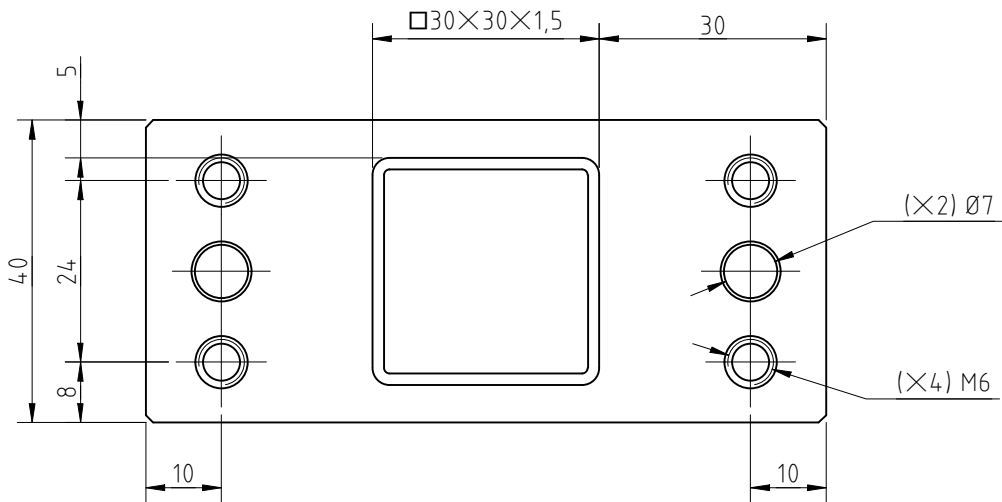

Smussare tutti i fori  $0,5 \times 45^\circ$

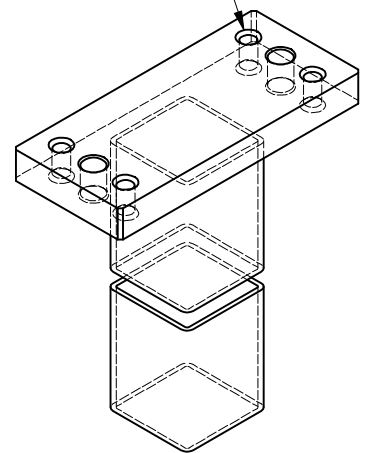

Titolo:  
Estensione attacco macchina

Progetto:  
REPAR2 PR

Colore:  
RAL1007

Massa:  
0,663 kg

Data:  
13/11/2022

Scala principale:  
1 : 1

Tolleranze dimensionali generali:  
UNI EN 22768-cL

Codice articolo:  
AS.SAL ATT\_L\_B

Numero disegno:  
004PR



Descrizione:

**Assieme saldato. Attacco macchina**  
Welded assembly. Machine connection..

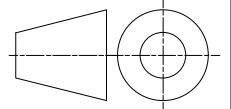

# C

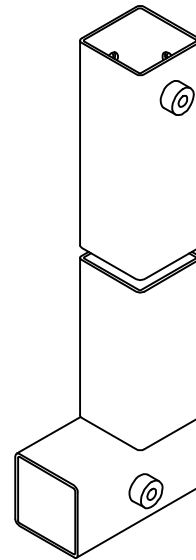
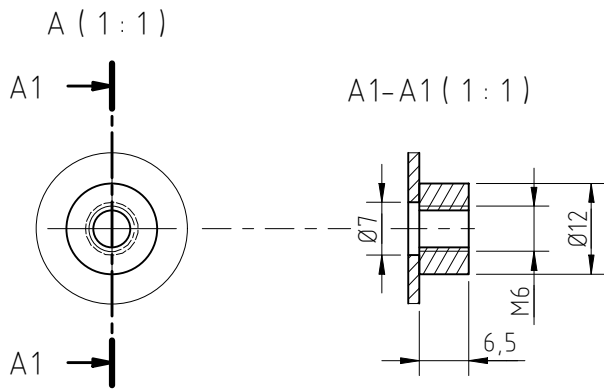
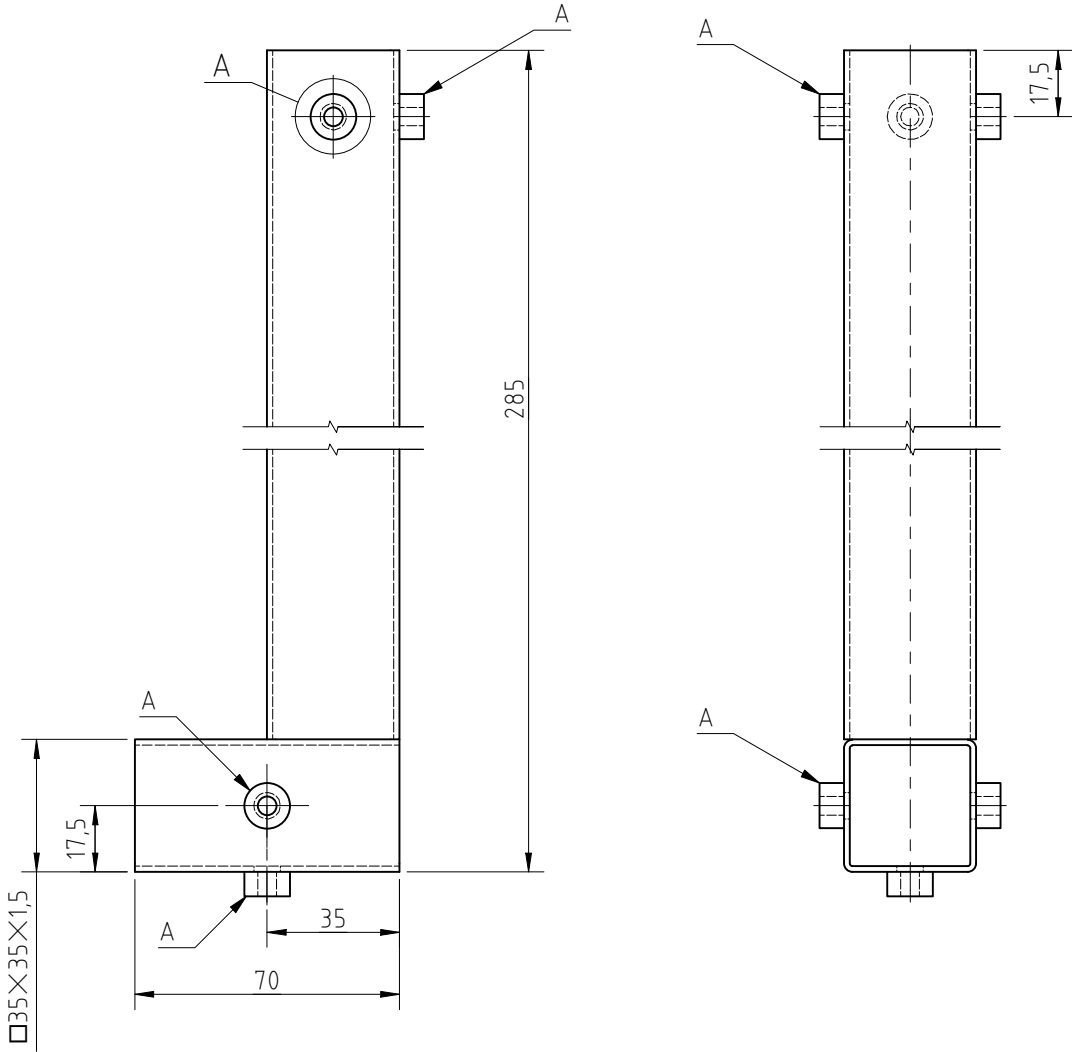

Tiolo:  
Guida per estensione attacco macchina.

Progetto:  
REPAR2 PR

Colore:  
RAL1007

Massa:  
0,521 kg

Data:  
13/11/2022

Scala principale:  
1 : 2

Tolleranze dimensionali generali:  
UNI EN 22768-cL

Codice articolo:  
AS.SAL ATT\_L\_A

Numero disegno:  
003PR



Descrizione:

**Assieme saldato.  
Welded assembly.**

